

Geologic Sequestration of Carbon Dioxide

Development of a Regulatory Framework



Stephen Heare

**U.S. Environmental Protection Agency
Office of Ground Water and Drinking Water**

March 4, 2008

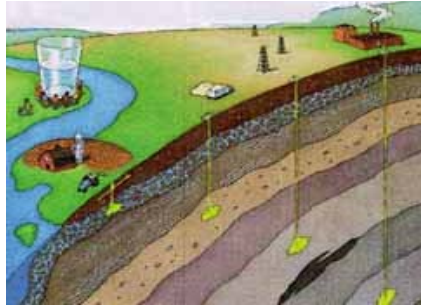

Briefing Outline

Geologic Sequestration of CO₂

- Importance of geologic sequestration
- Update on EPA activities
- Regulatory development process
- Approach to proposed regulation
- Update on recent stakeholder meeting

CO₂ Capture and Storage

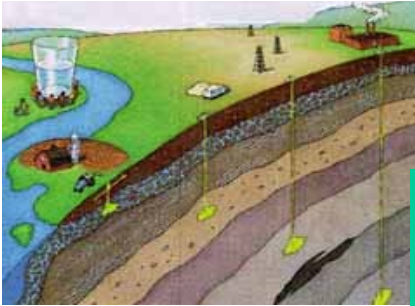

CO₂ Capture and Transport

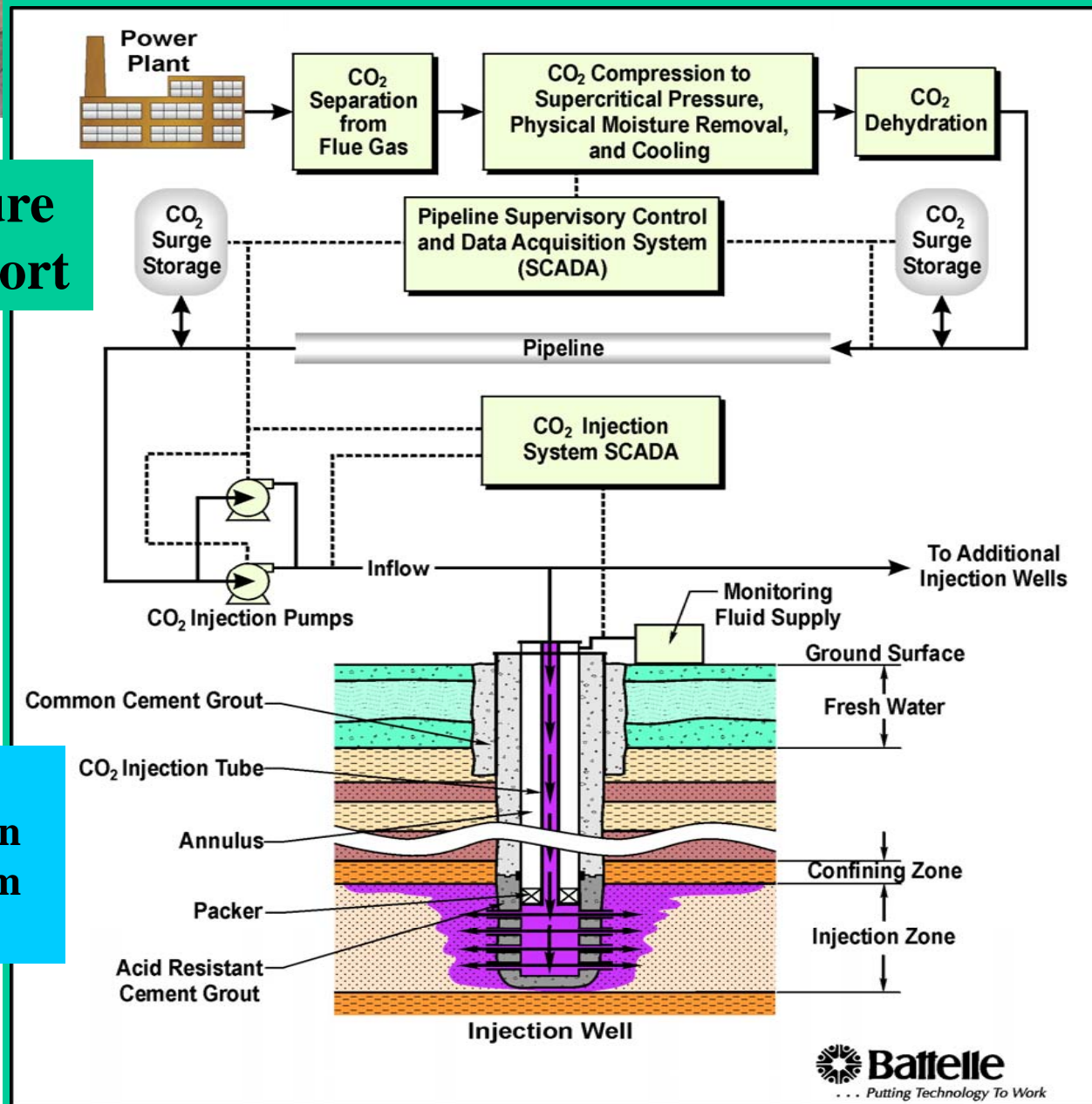

Geologic Sequestration UIC Program Scope



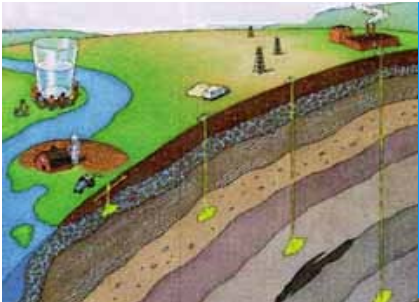

Potential U.S. Deployment

2020



2035

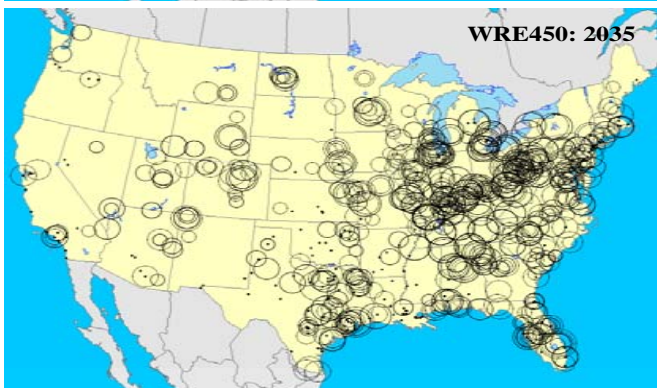

2050

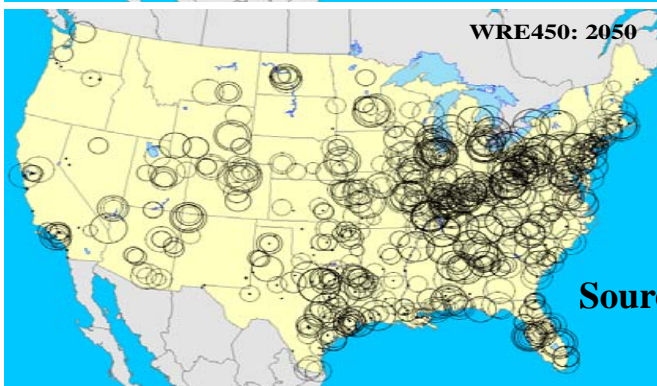

U.S. electric utility sectoral deployment of carbon dioxide capture and storage (CCS)-enabled generation systems

Cumulative Storage

- No active CCS
- 0 - 0.1 MtCO₂
- 0.1 - 1 MtCO₂
- 1 - 10 MtCO₂
- 10 - 50 MtCO₂
- 50 - 100 MtCO₂
- 100 - 250 MtCO₂
- 250 - 500 MtCO₂

Source: Battelle



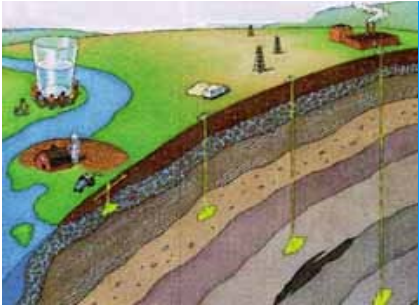

Successful Deployment

Geologic Sequestration of CO₂

- While Carbon Capture and Storage (CCS) is not a “silver bullet,” it is a key climate change mitigation technology
- Ensuring that permitting regulations are in place will enable commercial-scale CCS projects to move forward
- Clear guidelines will reduce uncertainty for project proponents
- Past experience gives us confidence that we can work closely with key stakeholders to develop well-designed regulatory approaches

“By harnessing the power of geologic sequestration technology, we are entering a new age of clean energy – where we can be both good stewards of the Earth, and good stewards of the American economy.” - EPA Administrator Stephen L. Johnson



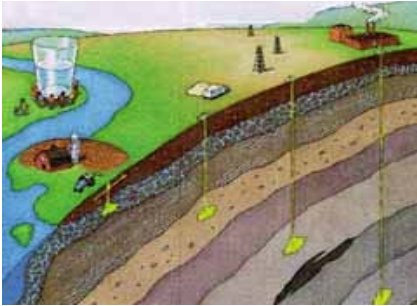

Update on EPA Activities

Geologic Sequestration of CO₂

- Consensus on the applicability of the SDWA to GS of CO₂ (January 2006, December 2007)
 - SDWA UIC program covers injection of any fluids including gases into the subsurface.
 - The UIC regulations address the siting, construction, operation, and closure of injection wells to protect drinking water and human health.
- Coordination with EPA Office of Air and Radiation and U.S. Department of Energy
- Published UIC Class V Experimental Technology Well Guidance (March 2007)
- Industry has already begun to request permits for initial GS pilot-scale projects and commercial projects
- Holding Technical Workshops (ongoing)
- Developing proposed rule (Summer 2008)



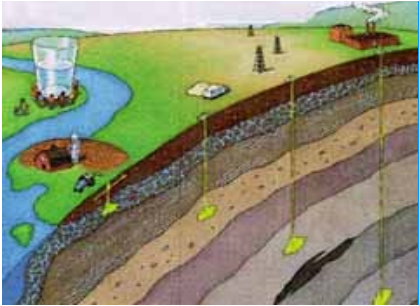

Regulatory Development

Geologic Sequestration of CO₂

- Hold stakeholder Meetings
- Engage EPA Workgroup that includes members from DOE, state permitting agencies
- Develop preamble and regulatory language for rule for publication in Summer of 2008
- Seek comment on options for permitting Geologic Sequestration of CO₂
- Publish Notice of Data Availability (NODA)

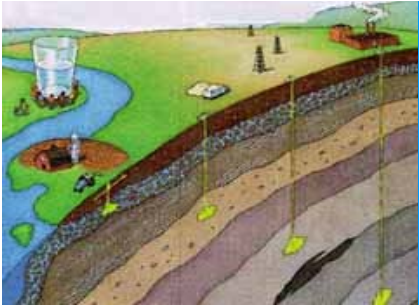

Regulatory Development

Geologic Sequestration of CO₂

- The proposed regulation will address the following technical elements:
- Geologic Siting – A detailed characterization of the site specific geology and confining unit to identify site suitability
- Area Of Review – The vertical and horizontal area surrounding an injection well; size determined by factors such as number of wells and site specific geology; assessing the potential for migration of injected and formation fluids into a USDW
- Well Construction Standards – Technical criteria applicable to materials used in building an injection well
- Mechanical Integrity Testing – Methods for evaluating wells capability to perform as designed
- Operation and Monitoring Requirements – Use of instrumentation to assess injection pressure, flow rate and volume
- Well Closure and Post-Closure Care– Technical criteria used to assure proper plugging and abandonment of the injection well



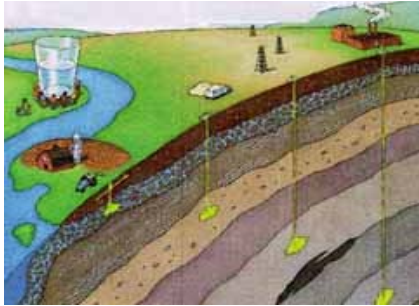

Milestones

Geologic Sequestration of CO₂

Activity	Milestone
Data Collection and Analysis	Ongoing
Two Stakeholder Meetings	December 2007/February 2008
Interagency Review of Proposed Rule	Late May - Early June 2008
Administrator's Signature of Proposed UIC Rule	July 2008
Public Comment Period for Proposed Rule	July – October 2008
Notice of Data Availability (if appropriate)	2009
Final UIC Rule for GS of CO ₂	Late 2010 / Early 2011



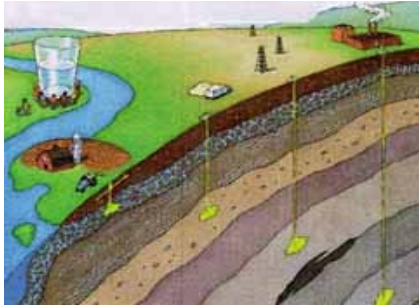

Stakeholder Issues

Geologic Sequestration of CO₂

- December 2007 public meeting was attended by over 250 stakeholders in government, industry, public interest groups
- Issues of concern identified included:
 - Technical Issues:
 - Area of Review determination and site characterization
 - Monitoring plume location and movement
 - Identification of the properties of CO₂ in the subsurface
 - Policy Issues:
 - Relationship between primacy state and federal authorities
 - Property rights, surface access rights, and pore space ownership
 - Post-closure care requirements
 - Overarching Issues:
 - Public education and outreach
 - Rule flexibility, adaptability, and cost



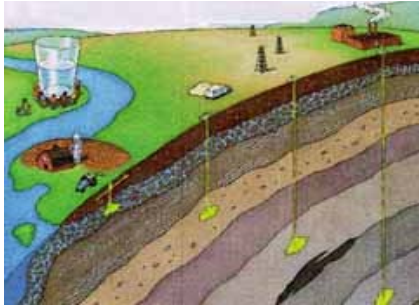

Stakeholder Issues

Geologic Sequestration of CO₂

- February 2008 public meeting attended by over 250 stakeholders from government, industry, public interest groups, and the public
- Updated stakeholders on current thinking on major elements of the rulemaking and sought specific feedback in plenary and breakouts on the following questions:
 - Should **well construction** of existing Class V experimental wells be ‘grandfathered’?
 - Stakeholder discussion generally indicted ‘yes,’ because constructing an entire new well wouldn’t be feasible
 - How should Class II wells injecting CO₂ be distinguished from GS wells?
 - Some industry support for grandfathering all ER wells, others recommended looking to pressure to define a distinction.
 - Note: oil/gas formations provide <10% of GS storage capacity in US
 - Should the following be required:
 - a secondary containment/confining system?
 - Discussion focused on redefining the question to “should rule require identification of additional zones that can provide confinement and monitoring opportunities?” Many thought there would be advantages, but that requiring it was prohibitive.
 - periodic re-evaluation of AoR?
 - Generally yes, this could bring more flexibility and other benefits

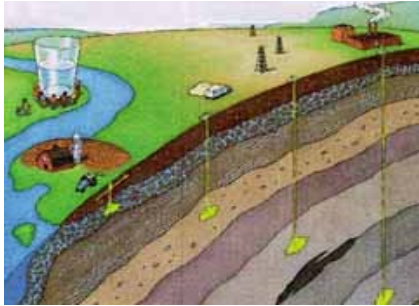

Stakeholder Issues

Geologic Sequestration of CO₂

- Should tracers or surface air / soil gas monitoring be required?
 - These techniques are still mainly in research stages, so should not be required. They also have some drawbacks for consideration.
- Should the owner/operator be required to maintain financial assurance for corrective action, remediation and post closure monitoring in addition to well closure? If so, for what timeframe?
 - Mostly yes, though some dissenters said that costs would be prohibitive and it would not provide certainty. Timeframe was debated
- Should the notification process be adapted to incorporate new technologies?
 - The idea of flexibility was generally well regarded.
- Should stakeholders be engaged earlier in the permitting process?
 - Discussion focused on engaging stakeholders at multiple stages during the process, which could include earlier stages.

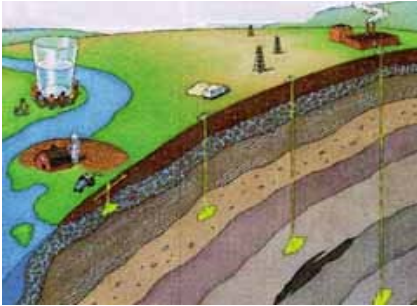

Questions and Discussion

Proposed UIC Rule for GS of CO₂

More information about the UIC Program

- + EPA Geologic Sequestration of Carbon Dioxide Website – http://www.epa.gov/safewater/uic/wells_sequestration.html
- + Code of Federal Regulations: Underground Injection Control Regulations 40 CFR 144-148 – http://ecfr.gpoaccess.gov/cgi/t/text/text-idx?sid=d6ee71a544eca89c533c825135913f13&c=ecfr&tpl=/ecfrbrowse/Title40/40cfrv22_02.tpl

